

60 second multi-segment solid sound recorder and playback module (ISD2560/ISD2590)

60-second multi-segment solid sound recorder combines an ISD2560/ISD2590, a microphone and an audio amplifier to form a complete high performance solid state sound record/replay module with a total sound recording length of 60/90 seconds. The message can be divided into 10 segments. A pushbutton switch selects the start of a segment. The first 9 segments are 6.4/9.6 seconds. The last segment is 2.4/3.6 seconds.



Sound is recorded either via an on-board microphone or via an audio line-in input. It requires a power supply from 4.5 V to 6.0 V DC. In record and replay modes, current consumption is typically 25mA. In idle mode, the current drops to 7mA. The module is measured 60mm×80mm×15mm. The module is shown in Figure 1.

1. The connection

Connection from the module to external circuitry is made through a 22-way double-sided edge connector (side A: A1 to A11 and side B: B1 to B11).

There are 11 connector pins on each. Pin functions of the module are shown in the following table. P/-R, PD, -CE, -EOM and -OVF correspond to the pins on the ISD2560/ISD2590 sound chip.

Figure 1 YAN4 solid state sound record/play module.

Pins		A1	A2	A3	A4	A5	A6	A7	A8	A9	A10	A11
Function	ISD2500	P/-R	PD	-CE	-EOM	-OVF	Line In	SP+	SP-	LM386 OUT	LM386 Vcc	Vcc

Pins		B1	B2	B3	B4	B5	B6	B7	B8	B9	B10	B11
Segment		1	2	3	4	5	6	7	8	9	10	GND

2. How to use the module

A typical connection of the module is shown in Figure 2. In this circuit, **S1** is a pushbutton switch, which is used to record sound. Speaker is an 8 Ohm speaker. **B1** to **B10** are pushbutton switches. Supply voltage is between 4.5V to 6V.

There are a number of soldering pads on the PCB board which setup the operation modes of the module (*Jm* and *Jl* are on the component side near the microphone and *Jc* is on the track side of the PCB board).

If microphone is used, *Jm* should be connected (*Jl* should be left open). If line-in input is used, *Jl* should be connected (*Jm* should be left open). The line-in voltage should be < 50 mV p-p.

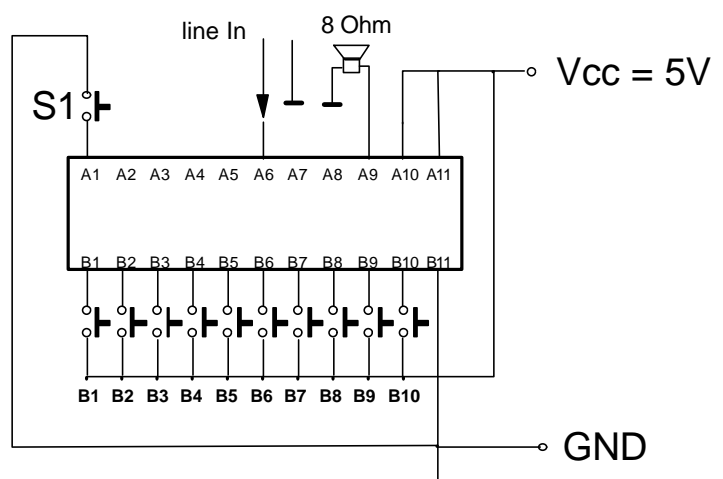

Figure 2 Application circuit diagram. If microphone is used, *Jm* is soldered together (*Jl* is left open). If line-in input is used, *Jl* is soldered together (*Jm* is left open).

Soldering *Jc* together enables the selected segmental sound to be played again and again as long a pushbutton is pressed continuously.

Jb (Pin 24 of ISD and Pin 3 of 555) controls the sound reply mode.

3 Sound recording and replaying

Mode 1 - *Jb* connected

Press **S1** button and one of switches from **B1** to **B10** together causes the module to record sound. Releasing the **switch** terminates recording. If recording time exceeds 60s, the green LED will be on and sound recording will be automatically terminated. During recording, users can either record sound via the microphone or via the audio line in (Line-in pin). When the audio line-in is used, the input signal level should be < 50 mV p-p.

Press **B1** through to **B10** button causes the module to replay sound from a particular segment. When the switch is released, the sound is stopped.

Notes on record and play segmental sound

Pressing button B1 to B10 only determines the start of a sound segment. Total length of sound record/play depends on how long the switch is pressed. This is explained in the following table. This table is for ISD2560 (60 second recording length). For ISD2590 (90 seconds recording length), the record/play start and total recording time will be increased accordingly.

Push and hold	Record or play sound start (ISD2560/ISD2590)		
B1 switch	Record or play sound from	0.00 / 0.00 seconds	Onwards to 60 / 90 seconds
B2 switch	Record or play sound from	6.40 / 9.6 seconds	Onwards to 60 / 90 seconds
B3 switch	Record or play sound from	12.8 / 10.2 seconds	Onwards to 60 / 90 seconds
B4 switch	Record or play sound from	19.2 / 28.8 seconds	Onwards to 60 / 90 seconds
B5 switch	Record or play sound from	25.6 / 38.4 seconds	Onwards to 60 / 90 seconds
B6 switch	Record or play sound from	32.0 / 48 seconds	Onwards to 60 / 90 seconds
B7 switch	Record or play sound from	38.4 / 57.6 seconds	Onwards to 60 / 90 seconds
B8 switch	Record or play sound from	44.8 / 67.2 seconds	Onwards to 60 / 90 seconds
B9 switch	Record or play sound from	51.2 / 76.8 seconds	Onwards to 60 / 90 seconds
B10 switch	Record or play sound from	57.6 / 86.4 seconds	Onwards to 60 / 90 seconds

In order to play a complete sound segment without holding the key continuously, an external timer delay circuit (giving 6.4 / 9.6 seconds for ISD2560 and ISD2590) have to be used. When a button is pressed, the corresponding line will generate a delay. This is explained in the following table.

When a particular button is pressed	Delay on corresponding lines	When a particular button is pressed	Delay on corresponding lines
B1	6.4 / 9.6 seconds	B6	6.4 / 9.6 seconds
B2	6.4 / 9.6 seconds	B7	6.4 / 9.6 seconds
B3	6.4 / 9.6 seconds	B8	6.4 / 9.6 seconds
B4	6.4 / 9.6 seconds	B9	6.4 / 9.6 seconds
B5	6.4 / 9.6 seconds	B10	2.4 / 3.6 seconds

In this replay mode, after a sound track is replayed (by holding a particular button and then release it after the sound track is replayed), the module enters power saving mode in which it consumes 7 mA.

Mode 2 - PIN 24 to Ground.

It is noted that during recording, *Jb* should always be connected. After recording, the Pin 24 of the ISD IC can be disconnected from Pin 3 of 555 and then connected to the Ground to achieve the following replay mode:

Press **B1** through to **B10** button ONCE causes the module to replay sound from the beginning of a particular segment to the end of the message. This mode is advantageous if a complete sound track is to be replayed upon pressing a button once without holding it as in the other replay mode.

It is noted that if Pin 24 is connected the Ground, the module will consume 25mA continuously. No power saving is available in this mode.

4 Amplification stage

An 8 Ohm speaker can be connected directly to the module. The on-board LM386N-1 audio amplifier has a maximum output power of 0.7 W (12V supply voltage with 8 Ohm speaker). The output power to speaker can be adjusted using the potentiometer on board (marked W1 on the PCB board).

In cases where more powerful amplifier is to be used, sound signal can be extracted from SP+ and SP- pins of the module. Various audio amplifiers can be found from www.intec-group.co.uk.

Notes on on-board LM386N-1

Maximum supply voltage: 12VDC

Quiescent current: 5 mA at 12V, 3.5mA at 5V

Output power with 8 Ohm: 800 mW (at 12V supply), 300 mW (at 6V supply)

5. Tips to obtain better sound quality

1. Use a good quality 8 Ohm speaker with *a cavity* such as these used for computer sound systems. Do not use a bare speaker that gives you poor sound quality.
2. For better sound quality, speak with a distance to the on-board microphone (marked MIC on the PCB board) and speak clearly. Also keep the backgrounds noise as low as possible. Record your sound in a quiet room.
3. For best sound quality, use the Line-In pin (Audio Line In). The audio signal is injected into the module between Line-In and Ground.
4. Always connect *Jb* during sound recording.

6. Evaluation board

The evaluation board has the following connectors

Power supply: Power supply (V+ and GND)

Speaker: Speaker outputs

Line-in: Line input

To record a sound track, press RECORD and one of the track buttons (1 to 10). To play the sound, press and hold one of the track button (1 to 10).

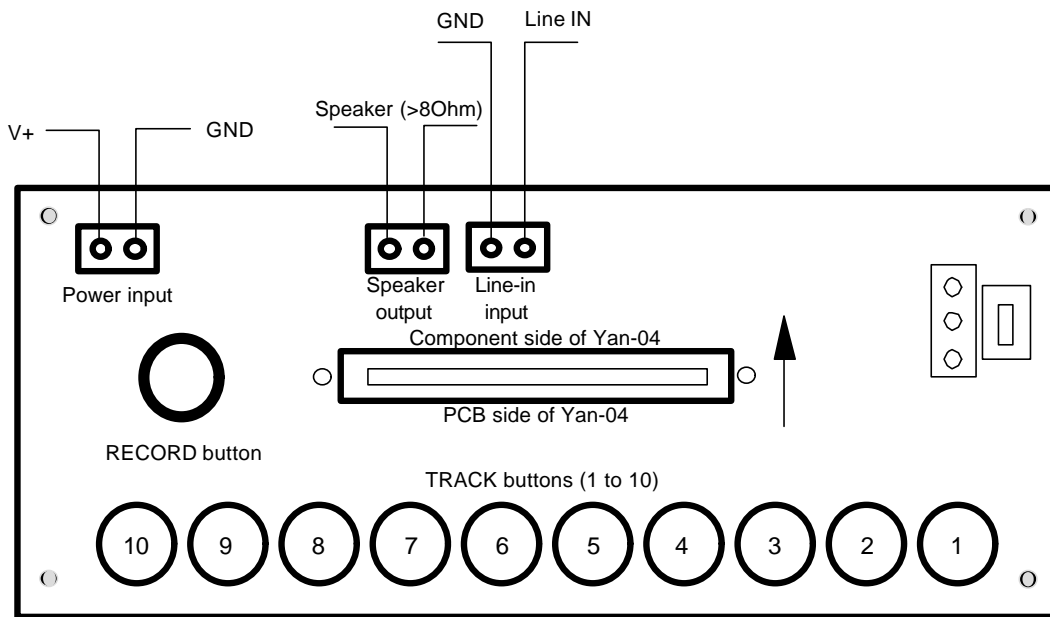

Figure 3 Evaluation board